

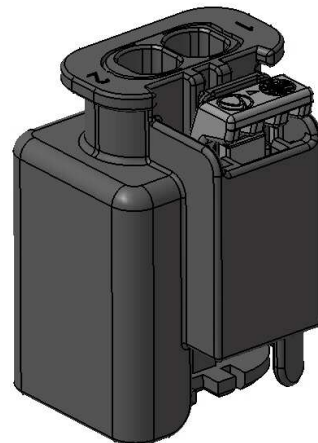

HIRSCHMANN
AUTOMOTIVE

Processing Specification

2-pin to 5-pin SLK Socket Housings

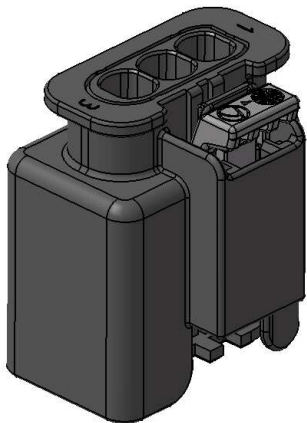
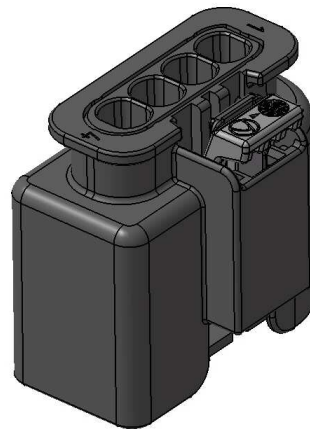
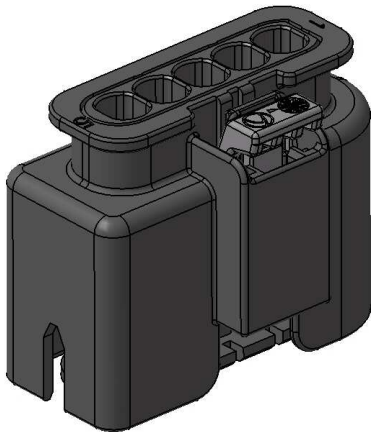

EVS-100016-00
Edition 00



1. Index

1. Index.....	2
2. General Information	3
2.1. Introduction	3
2.2. Applying relevant Information/Documentation	3
3. Delivery Condition / Product Components	4
3.1. Delivery Condition	4
4. Usable Contacts	5
4.1. Usable Contacts with SEAL	5
5. Assembling and Disassembling of SLK Contacts.....	6
5.1. Assembling of SLK Contacts.....	6
5.1.1. Primary Locking Mechanism.....	6
5.1.2. Secondary Locking Mechanism	6
5.2. Disassembling.....	7
5.3. Electric continuity test	7
6. Connection and Disconnection of connectors	8
7. Index change table	9



2. General Information

2.1. Introduction

This processing specification is valid for all water tight SLK housings mentioned and describes the delivery conditions, the product components as well as the assembling and disassembling of the housings and contacts.

Based on the processing specification for Sensor Lamina Contacts of the company Kostal the contact assembling and disassembling are described.

The processor of the products mentioned in this specification is responsible for the processing quality and the specified execution.

In case of an inappropriate deviating processing and subsequent quality problems the right of recourse will be rejected.

2.2. Applying relevant Information/Documentation

- | | | |
|----|--|---|
| a) | Processing Specification comp. Kostal
1 00 40 52535 0 | sensor lamina contacts SLK 2.8 |
| b) | „Deutsche Norm“
DIN EN 60352-2 | solder free electrical connection
part 2: crimp connection |
| c) | TB terminal comp Kostal
DOC00043218 | sensor lamina contacts SLK 2.8
female contact |
| d) | TB single wire sealing comp. Kostal
DOC00033206 | single wire sealing |



3. Delivery Condition / Product Components

3.1. Delivery Condition

The connector, consisting of contact housing, seal, additional protective shroud and CPA (optional) is being delivered in assembled condition, with pre-engaged CPA (optional).

To connect a protective cap a defined contour is provided.

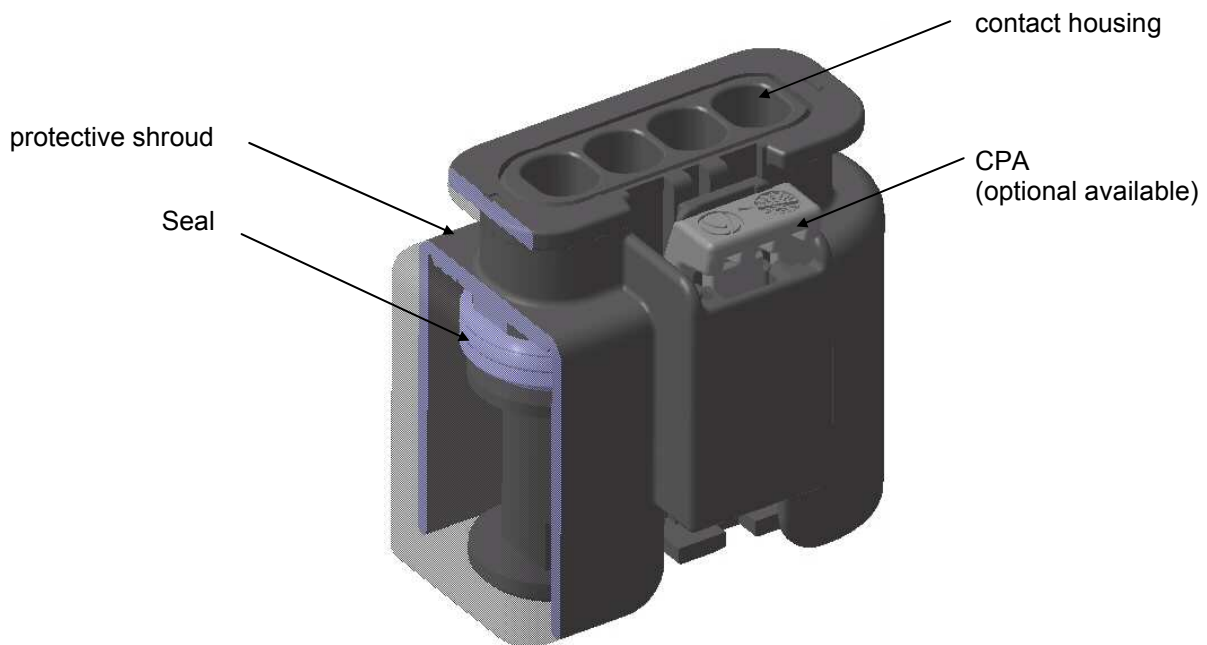



4. Usable Contacts

4.1. Usable Contacts with SEAL

Contact system with chambers for socket contact singular seal system see Kostal drawing SLK 2.8 receptacle, DOC00043218

Chamber-Ø: 5.2mm partly oblate to 4.4mm

Usable single wire seal 5.2 / single wire dummy plug 5.2 see

Kostal – drawing TB seal: DOC00033206

To guarantee the required tightness of the system it is absolutely necessary to use all contacts with corresponding seal and in case of reduced contact assembly to close the open chambers with a single wire dummy plug.

Corresponding processing tools, e.g. crimp tools, hand crimp pliers and removal tools see Kostal processing specification:

Sensor Lamina Contact SLK 2.8 DOC00074173

5. Assembling and Disassembling of SLK Contacts

5.1. Assembling of SLK Contacts

max. assembling force for a single wire with seal	
2.5mm ² wire	max. 45N
0.5mm ² wire	max. 20N

5.1.1. Primary Locking Mechanism

Contact housing is delivered ready for assembly. During assembling the primary locking mechanisms engage in the housing. The contact housings can also be assembled 180° twisted.

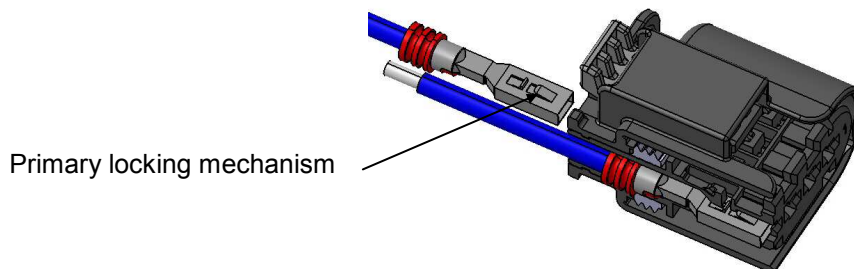

5.1.2. Secondary Locking Mechanism

When the SLK contacts are mounted in the socket housing (primary locking mechanism active) the secondary locking mechanism is activated automatically. Engaging of the secondary locking mechanism can be ensured by clicking.

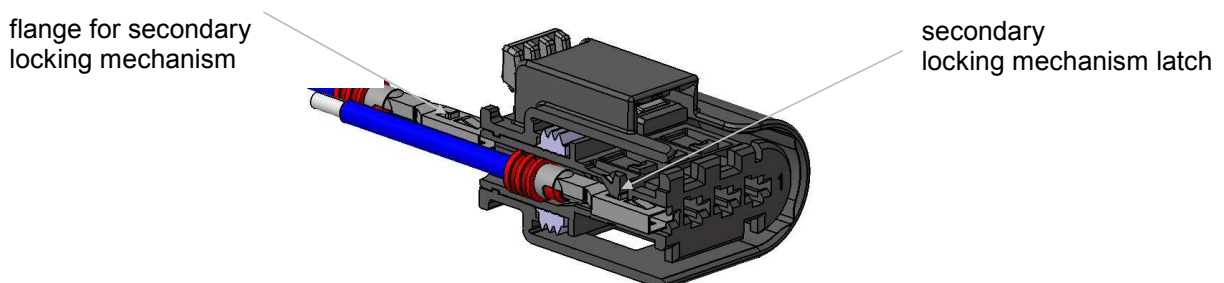

5.2. Disassembling

The socket contacts can be removed for repair.

According to the processing specification DOC 00074173 of the company Kostal a special dismantling tool (Kostal no. 2 72 00 54405 0) is inserted in the unlocking openings in order to deactivate primary and secondary locking mechanisms. Afterwards the contacts can be withdrawn by pulling back the wires slightly.

Alternatively a dismantling tool of the company TGS could be used. The tool with the order number S035, is also inserted in the unlocking openings and as a consequence the primary and secondary lockings are deactivated. Make sure not to harm the connecting zone of the contacts. Afterwards the contacts can be withdrawn by pulling back the wires slightly.

Because of the risk of damage the contacts have to be checked before further usage.

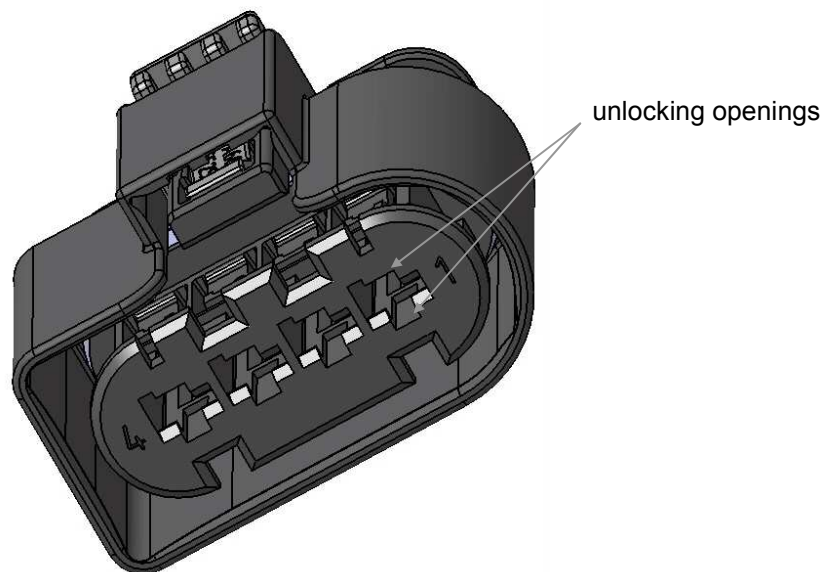

5.3. Electric continuity test

According to the processing specification of the company Kostal a specified test pin is used to detect unseated terminals during terminal installation and continuity tests. The connector provides access for the continuity test through the front.

The test pin must neither make physical contact with the terminal mating surface nor be immersed into the receptacle. The maximum inspection force must not exceed.



6. Connection and Disconnection of connectors

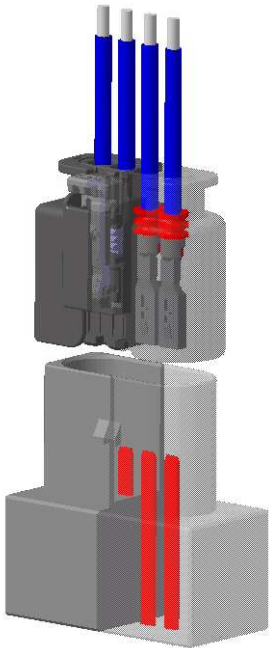

The plug-in connection is completed by inserting vertically in a suitable unit connection or pin housing until the clip is correctly engaged. Engaging of connector housing in counterpart is ensured by clicking. After a correct connection the CPA can be engaged with is also ensured by clicking.

Ideally the connector is inserted vertically in the suitable unit connection or pin housing by pulling directly on the CPA. In this case the connector and the CPA are engaged in one step.

The socket housing is held positively in the unit connector or in the plug connector. To disconnect the socket housing, firstly the CPA has to be put in the pre-engaged position until its flush with the connector. Afterwards the connector can be disconnected by deactivating the clip and pulling in the direction of the wire.

Not on any account it is allowed to disconnect the housing through pulling on the wire!

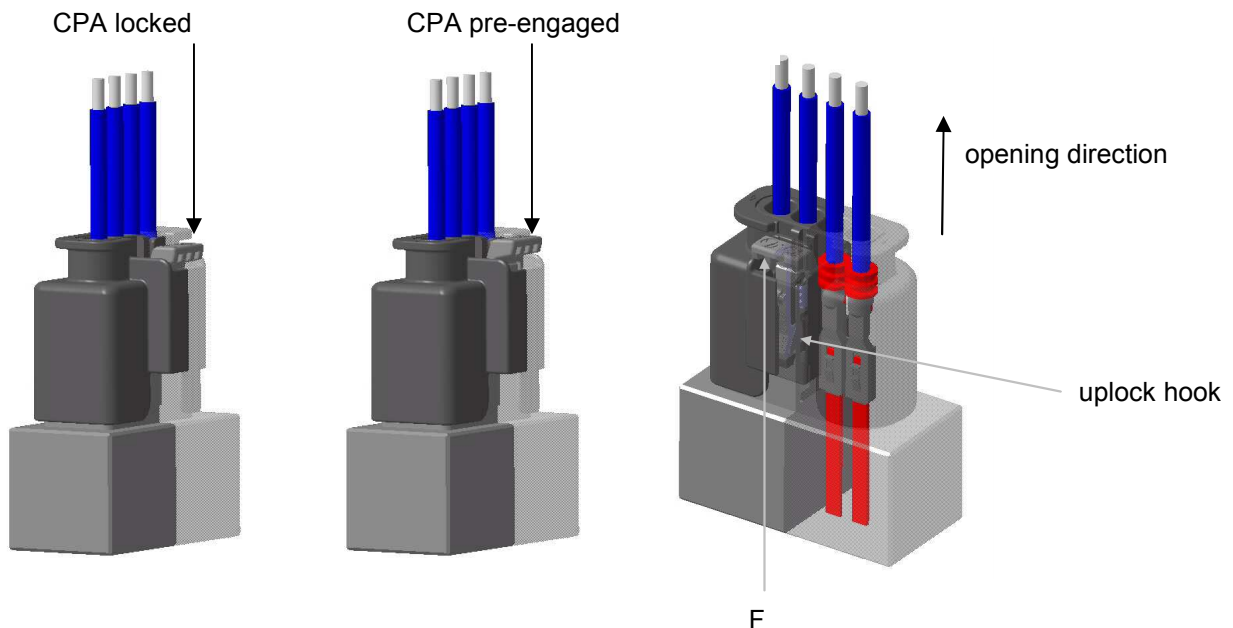



7. Index change table

Edition	Index	Editing
August 2014	first edition	Kiechle