



Handling Manual

1.2 SealStar Female Connector 2-row



EVS-100089-00
Version 01

1. Index

1. Index	2
2. General Information.....	Fehler! Textmarke nicht definiert.
2.1. Introduction.....	3
2.2. Applicable Specification and Documentation.....	Fehler! Textmarke nicht definiert.
3. Delivery Condition / Product Components.....	Fehler! Textmarke nicht definiert.
3.1. Delivery Condition housing (CPA optional).....	Fehler! Textmarke nicht definiert.
4. Terminals.....	Fehler! Textmarke nicht definiert.
5. Suitable dress covers, delete caps or transport caps	6
6. Insertion and Removal of 1.2 Contacts from the Connector.....	7
6.1. Primary Lock.....	7
6.2. Secondary Lock.....	8
6.3. Removing of the 1.2 Contact.....	9
7. Connect and disconnect of a Connector	10
7.1. Connect the female housing with CPA.....	10
7.2. Disconnect the female housing with CPA.....	10
8. Index change table.....	Fehler! Textmarke nicht definiert.

2 General Information

2.1 Introduction

This handling manual is valid for all variants, keys and options of the 2-row 1.2 SealStar female connectors and describes the delivery conditions, the individual components as well as the assembly and disassembly of the connector and terminals.

Based on the processing specification from the contact supplier the contact assembly and disassembly is described.

The harness maker is responsible to follow all processing specification and other relevant rules and regulations.

In case of inappropriate/incorrect assembly a damage claim will be rejected



2.2. Applicable Specification and Documentation

a) Application Specification (TE) 114-18464	MCON 1.2mm Contact System
b) Product Specification (TE) 108-18782	Multi Contact point MCP 1.2
c) Processing Specification (Kostal) DOC00061540	Mini Lamina Contacts MLK 1.2
d) Product Specification (Kostal) DOC00076784	Mini lamina contacts MLK 1.2
e) „Deutsche Norm“ DIN EN 60352-2	Solder-Free Electrical Connection Part 2: Crimp Connection
f) MCON 1.2-LL Contact MCON 1.2-LL: C-1452674	MCON 1.2-LL socket contact (TE)
g) MLK Contact MLK-Sm 1.2: DOC00079128	MLK 1.2 jacks (Kostal)

3. Delivery Condition / Product Components

The housings are generally packaged and delivered as bulk goods.

In very rare cases, it may occur that the CPA moves into final locking or closes the secondary lock.

In the case of the closed secondary lock, this can be adjusted according to point 6.3. To be returned to the initial state.

If the CPA is in final locking, this can be adjusted according to point 7.2. Into the delivery condition.

3.1 Delivery Condition housing (CPA optional)

The connector consists of a protective shroud, a seal, a contact carrier and an optional CPA. The contact carrier is pre-assembled in the shroud, the secondary lock is open and optional a pre-engaged CPA

To connect a protective cap a defined contour is provided.

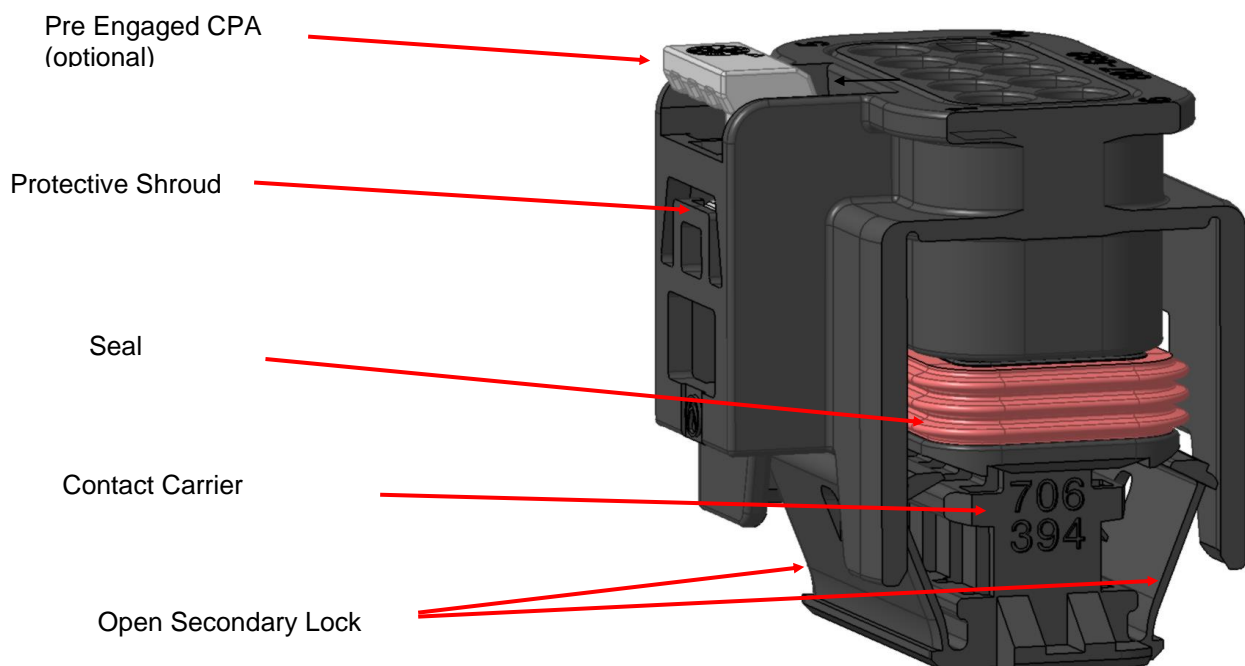

4. Terminals

Please see terminal manufacturer drawing for processing requirements

To guarantee the required sealing performance the terminals and seals must fit the wire and all open cavities must be plugged with cavity plugs (except if the cavity is pre-flashed).

Crimp tools, e.g., applicators, hand crimp tools and removal tools please see process specification of the terminal manufacturer.

5. Suitable dress covers, delete caps or transport caps

Appropriate mounting parts are available for the housings.
Details on the availability can be found in the customer's drawing or clarified with the respective manufacturers

6. Insertion and Removal of 1.2 Contacts from the Connector

6.1. Primary Lock

The connector is delivered ready for assembly.
The contacts are inserted in the connector until a click is audible

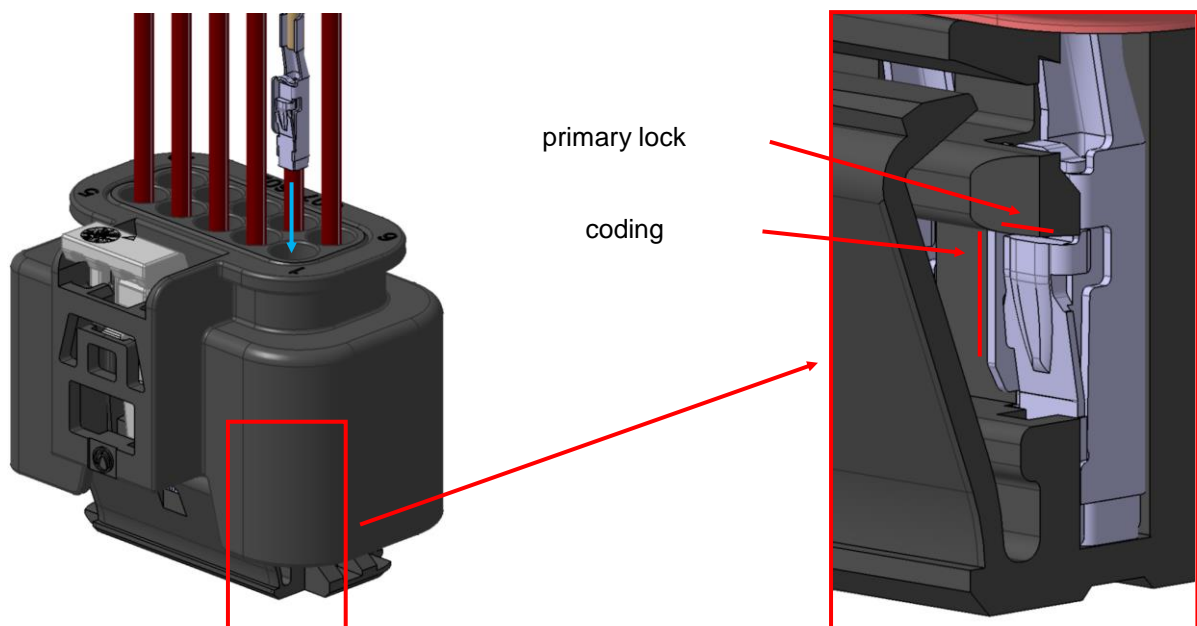

6.2. Secondary Lock

After the terminals are inserted into the contact carrier (primary lock active), the secondary lock must be activated by pressing the latch.

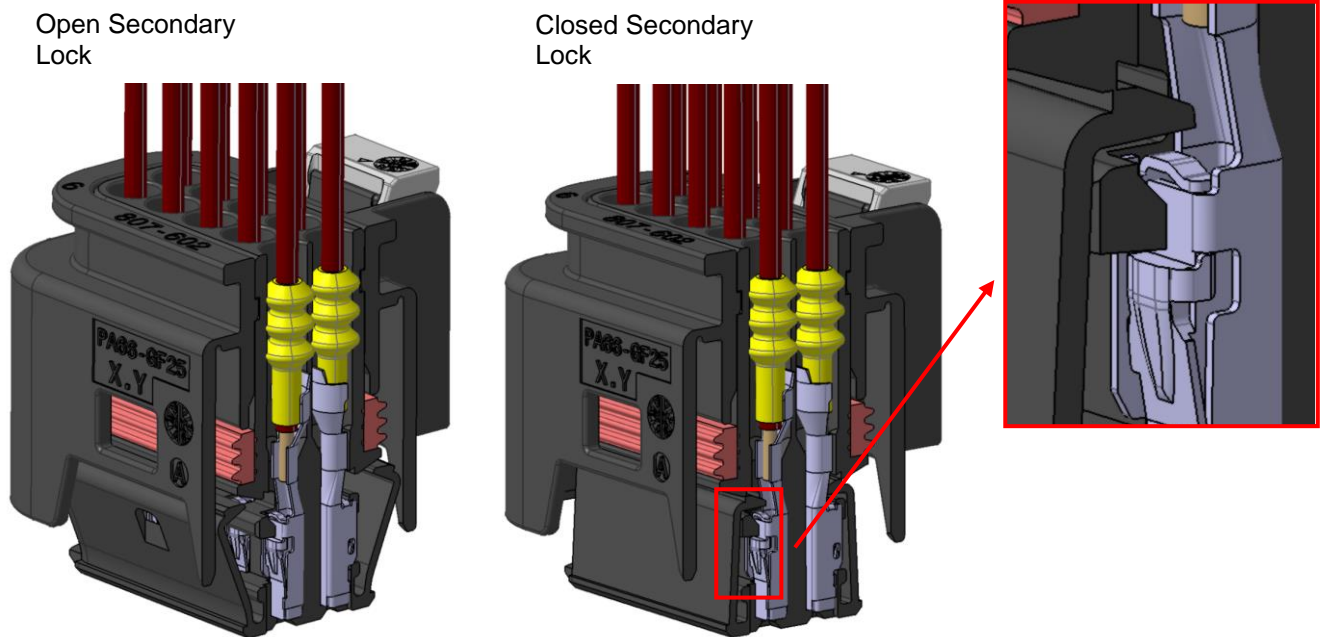

To close the secondary lock, press the latch on minimum 2 points along the red line

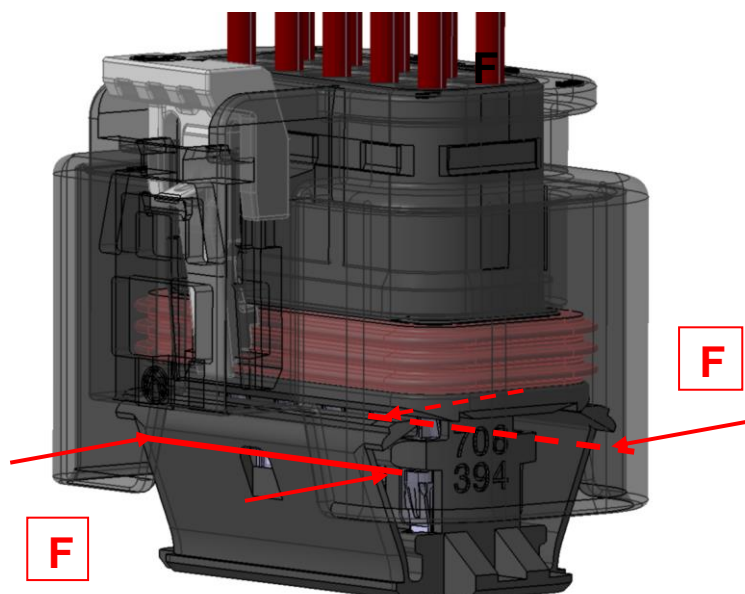

6.3. Removing of the 1.2 Contact

The contacts can be removed for repair. First the secondary lock must be opened.

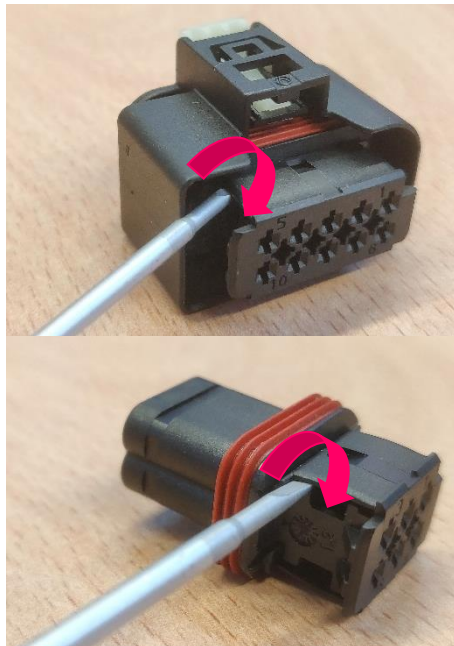

(symbol image)

A small screwdriver may be used in order to open secondary lock latch by carefully turning the screw driver. Do not bend the latch more than original delivery condition, don't damage the contacts.

The primary lock of the terminal can be opened and the terminal can be removed (following the process specification of the terminal manufacturer).

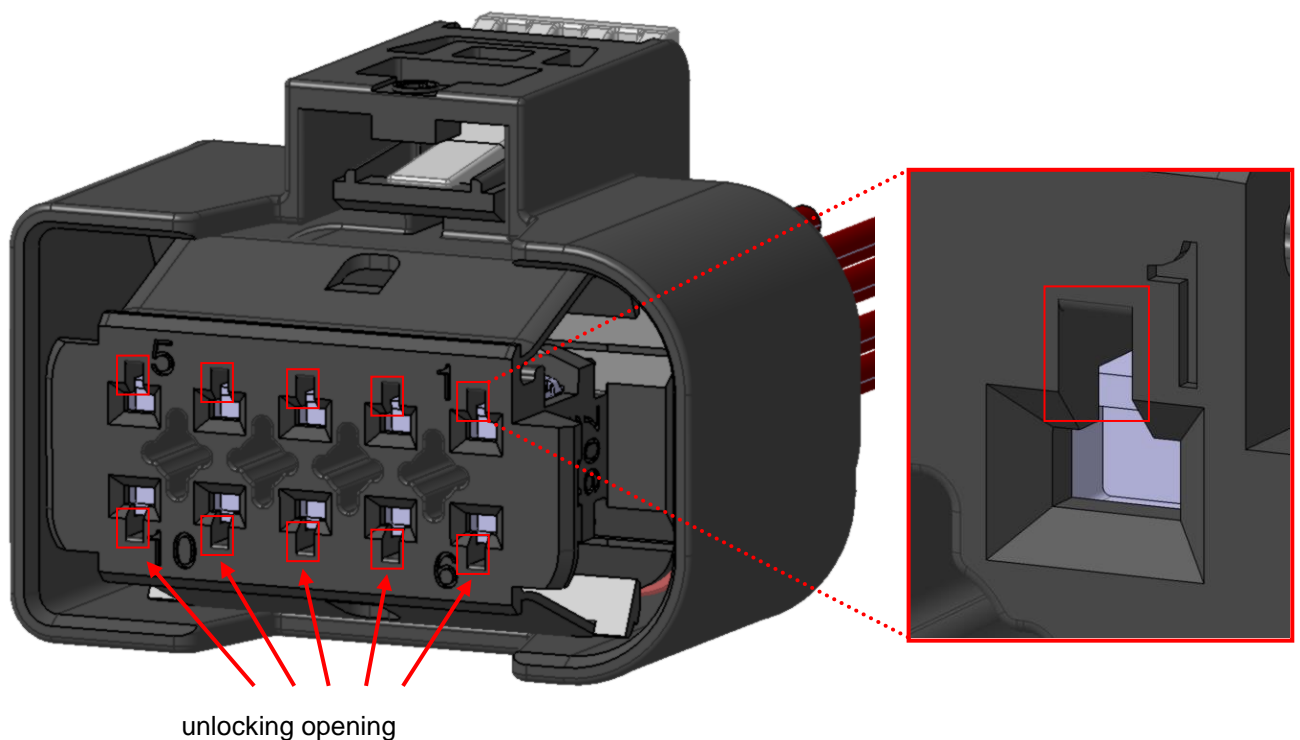

unlocking opening

7. Connect and disconnect of a Connector

7.1. Connect the female housing with CPA

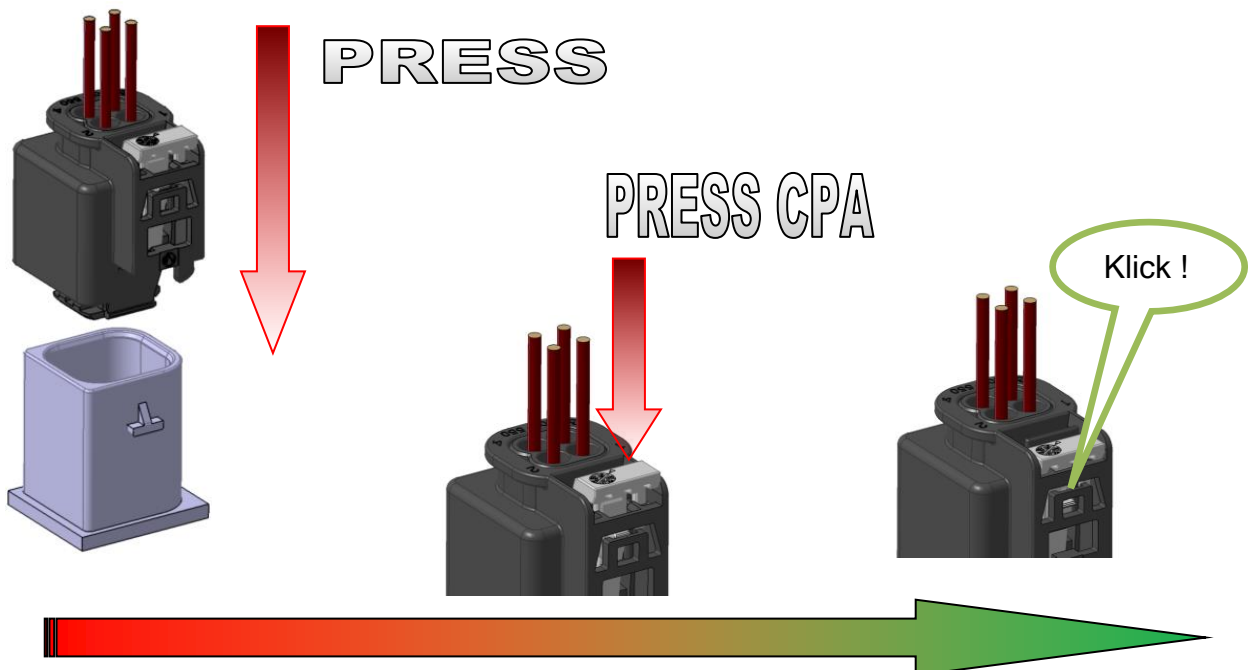

7.2. Disconnect the female housing with CPA

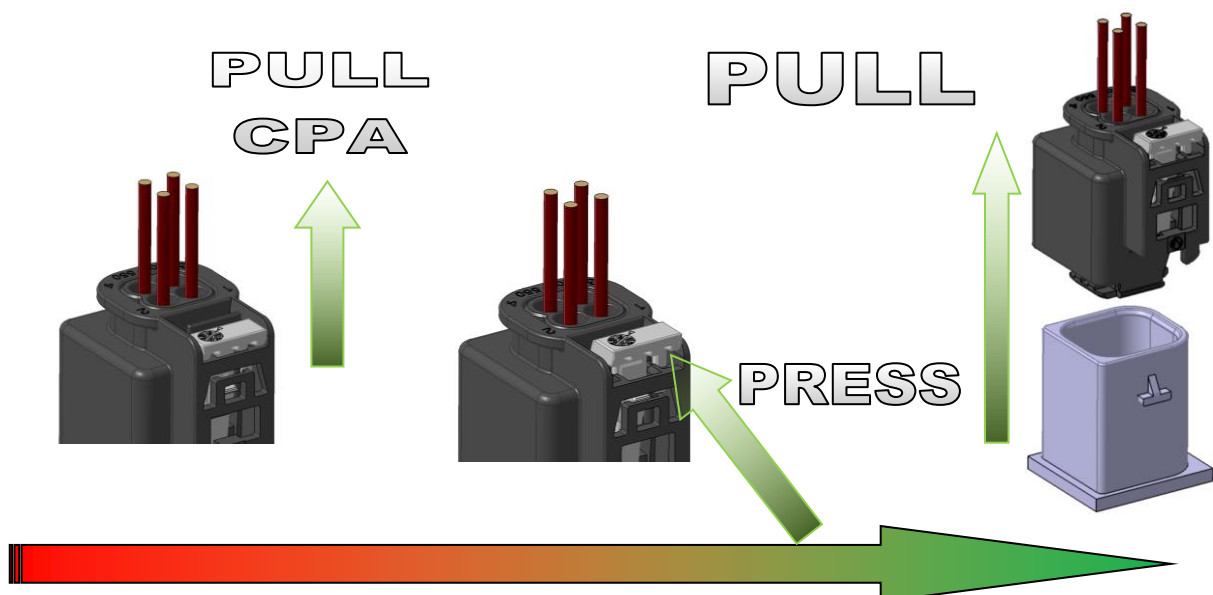

8. Index Change Table

Version	Description of change	Name
00	First edition	Bürk
01	Template Update	J. Valtierra