



PROCESS SPECIFICATION  
**HPS40-1 2+2**  
**Female Connector SCC**

EVS-100180



HIRSCHMANN  
AUTOMOTIVE



# TABLE

1.	General .....	2
1.1	Introduction .....	2
1.2	Other current documents.....	3
2	Product structure (single components) .....	4
2.1	Sheated cable (see table).....	4
2.2	HPS40-1 2+2 locking sleeve .....	5
2.3	HPS40-1 2+2 female contact carrier.....	6
2.4	HPS40-1 2+2 shielding sleeve .....	7
2.5	HPS40-1 2+2 stress relief .....	8
2.6	HPS40-1 2+2 wire seal.....	9
2.7	HPS40-1 2+2 cover Cap .....	10
2.8	female terminal HCT4 .....	11
3	Process steps.....	12
3.1	Cut the shielded cable.....	12
3.2	Assembly the single components .....	13
3.3	Strip insulation of shielded cable .....	14
3.4	Wire processing I.....	15
3.5	Wire processing II.....	16
3.6	Assembly I.....	17
3.7	Assembly II - female terminal HCT4.....	23
3.8	Assembly III.....	26
3.9	Positioning locking sleeve unit.....	28
3.10	Assembly seal and cover cap.....	30
3.11	Delivery of produced harnesses .....	30
4	Technical information .....	31
4.1	General requirements.....	31
4.2	Technical cleanliness .....	31
5	Change of documentation .....	32

This document is not subject to change service!



# 1. General

## 1.1 Introduction

This process specification is valid for all versions and describes the product structure as well as the manufacturing of the HPS40-1 2+2 female connector SCC.

System number	Coding	HVIL Version	Wire cross section	CPA version
805-972-021	A	Yes	3.0 mm <sup>2</sup> 5.0 mm <sup>2</sup>	without CPA
805-972-022	B	Yes		
805-972-023	C	Yes		
805-972-027	Z	Yes		
805-972-028	A	No		
805-972-029	B	No		
805-972-030	C	No		
805-972-034	Z	No		
805-972-035	A	Yes		with CPA
805-972-036	B	Yes		
805-972-037	C	Yes		
805-972-041	Z	Yes		
805-972-042	A	No		
805-972-043	B	No		
805-972-044	C	No		
805-972-048	Z	No		

The manufacturer is responsible for the qualitative processing and the described version of the mentioned products in this process specification. In case of an incorrect processing, dissenting from this process specification, there will be no right of recourse in case of appearing quality problems.

This document is not subject to change service!



## 1.2 Other current documents

A	datasheet 3.0 mm <sup>2</sup> shielded cable of SUMITOMO	ETS-17051
B	datasheet 5.0 mm <sup>2</sup> shielded cable of FORCE	M6040
C	datasheet 5.0 mm <sup>2</sup> shielded cable of JUDD	JW1280-09
D	Process specification mini lamina contact MLK 1,2	DOC 00061540 ÄSD10 / March 2008
E	Process specification HCT4 female terminal	EVS-100068
F	datasheet 3.0 mm <sup>2</sup> shielded cable of COFICAB	t.b.d.





## 2 Product structure (single components)

### 2.1 Sheated cable (see table)

Wire manufacturer	Wire cross section	
	3.0 mm <sup>2</sup>	5.0 mm <sup>2</sup>
<b>Coficab</b>	FHLR91XC91X T4	-
<b>Sumitomo Electric Interconnect Products (Suzhou) Ltd.</b>	SUMITOMO-SZ EXZSW-F 3 150° C, 600 V	-
<b>Judd Wire Inc.</b>	-	1C BC XLPO/XLPO; SHIELDED, ISO 150° C, 600 V, HEV
<b>Beijing Force Automotive Wire Co. Ltd.</b>	-	FORCE-S61-2009 150°C, 600 V
<b>KBE</b>		FHLR91XC91X T4

This document is not subject to change service!

## 2.2 HPS40-1 2+2 locking sleeve

	
without CPA	with CPA
<b>Hirschmann Automotive No.</b>	<b>Wire cross section</b>
806-230-515	3.0 mm <sup>2</sup> 5.0 mm <sup>2</sup>
806-230-516	

Delivery condition: The locking sleeves will be delivered in PE-bag in cardboard-box.

This document is not subject to change service!



## 2.3 HPS40-1 2+2 female contact carrier

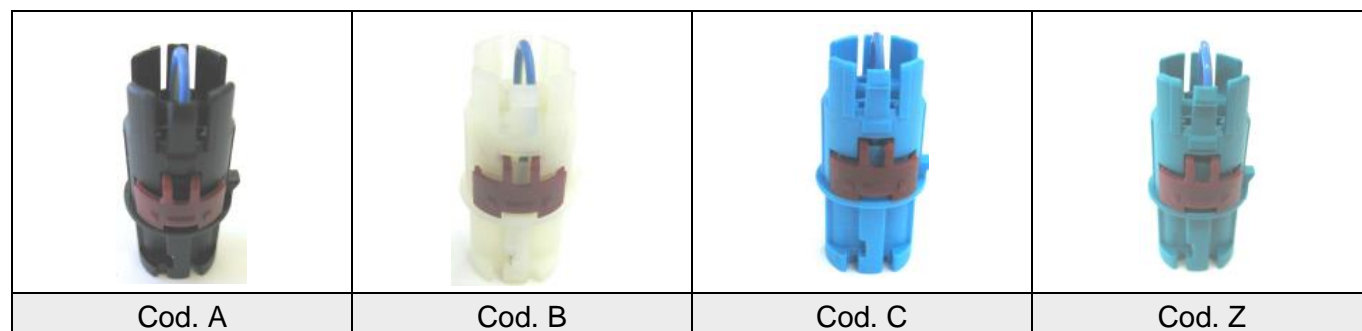

Hirschmann Automotive No.	Coding	Colour	HVIL bridge	Wire cross section
806-229-571	A	Black	Yes	3.0 mm <sup>2</sup> 5.0 mm <sup>2</sup>
806-229-572	B	Natural/ White	Yes	
806-229-573	C	Blue	Yes	
806-229-577	Z	Water-blue	Yes	
806-229-580	A	Black	No	
806-229-581	B	Natural/ White	No	
806-229-582	C	Blue	No	
806-229-586	Z	Water-blue	No	

Delivery condition: The female contact carriers will be delivered as bulk good.

This document is not subject to change service!

## 2.4 HPS40-1 2+2 shielding sleeve



-511

Hirschmann Automotive No.	Wire cross section
709-115-511	3.0 mm <sup>2</sup> 5.0 mm <sup>2</sup>

Wire manufacturer: The released HV cable for each shielding sleeve is shown on the product drawing. (Hirschmann Automotive no. 805-972-...00)

Delivery condition: The shielding sleeves will be delivered in BE-bag as bulk good.

This document is not subject to change service!



## 2.5 HPS40-1 2+2 stress relief



-501, -502

Hirschmann Automotive No.	Wire cross section
709-973-501	5.0 mm <sup>2</sup>
709-973-502	3.0 mm <sup>2</sup>

Wire manufacturer: The released HV cable for each stress relief is shown on the product drawing. (Hirschmann Automotive no. 805-972-...00)

Delivery condition: The stress relief will be delivered in BE-bag as bulk good.

This document is not subject to change service!

## 2.6 HPS40-1 2+2 wire seal



-501

Hirschmann Automotive No.	Colour	Wire cross section
709-972-501	Blue	3.0 mm <sup>2</sup> 5.0 mm <sup>2</sup>

Wire manufacturer: The released HV cable for each seal is shown on the product drawing. (Hirschmann Automotive no. 805-972-...00).

Delivery condition: The wire seals will be delivered as bulk good.

This document is not subject to change service!

## 2.7 HPS40-1 2+2 cover Cap



-501

Hirschmann Automotive No.	Wire cross section
706-541-501	3.0 mm <sup>2</sup> 5.0 mm <sup>2</sup>

Wire manufacturer: The released HV cable for each cover cap is shown on the product drawing. (Hirschmann Automotive no. 805-972-...00).

Delivery condition: The cover caps will be delivered as bulk good.

This document is not subject to change service!

## 2.8 female terminal HCT4



-504

Hirschmann Automotive No.	Wire cross section
709-427-504	3,0 mm <sup>2</sup> 5,0 mm <sup>2</sup>

Wire manufacturer: The released HV cable for each terminal is shown on the product drawing. (Hirschmann Automotive no. 805-972-...00).

Delivery condition: The female terminals will be delivered on the spool.

This document is not subject to change service!



## 3 Process steps

The following described process steps are used for the cross-sections 3.0 mm<sup>2</sup> and 5.0 mm<sup>2</sup>. The version with 5.0 mm<sup>2</sup> FORCE cable plus the terminal holder code A, were selected as reference.

### 3.1 Cut the shielded cable

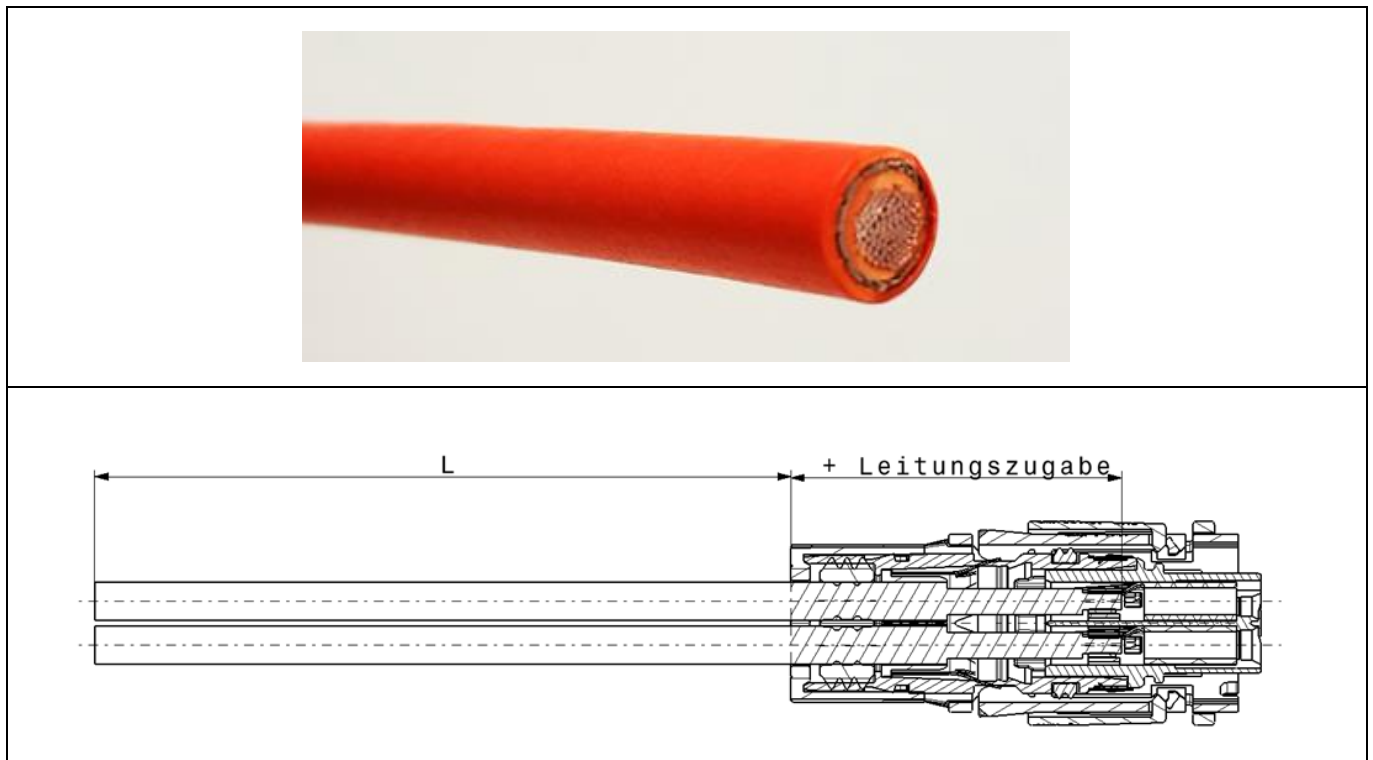

This dimension must be added to the planned length L at cutting process of the wire for each female connector.

Wire cross section	Wire add-on without zero-cut (mm)	Wire add-on with zero-cut (mm)
3.0 mm <sup>2</sup>	48.3	52.3
5.0 mm <sup>2</sup>	48.3	52.3

### 3.2 Assembly the single components

Push the cover cap (1), seal for wire (2), locking sleeve (3) and stress relief (4) onto the shielded cable.





### 3.3 Strip insulation of shielded cable



Stripping length:



Wire cross section	Dimension L1 for Hirschmann Automotive HCT4 terminal incl. zero-cut (mm)	Dimension L1 for Hirschmann Automotive HCT4 terminal excl. zero-cut (mm)
3.0 mm <sup>2</sup>	29.05 ± 1	25.05 ± 1
5.0 mm <sup>2</sup>	29.05 ± 1	25.05 ± 1

Do not cause any mechanical damages during the manufacturing processes.



## 3.4 Wire processing I

### Assemble stress relief, cut shielding braid

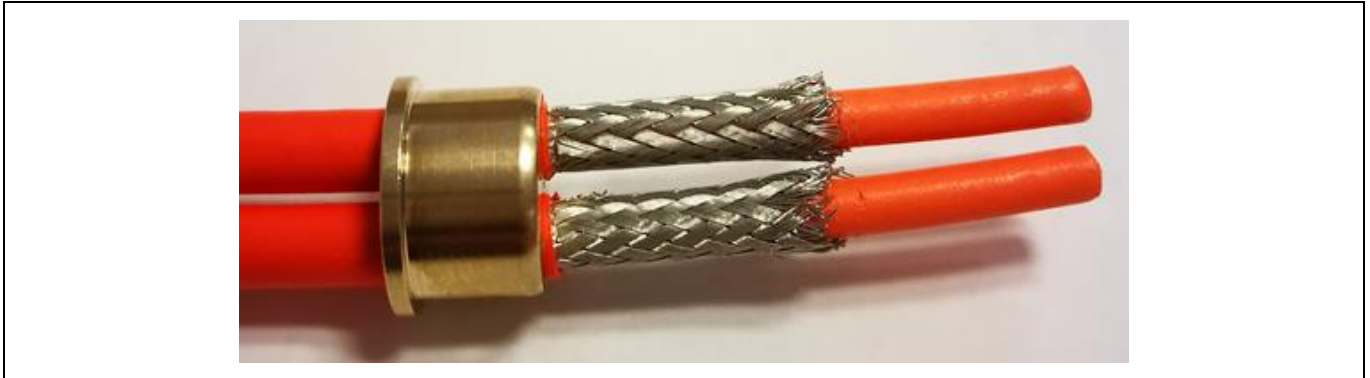

#### Length shielding braid:

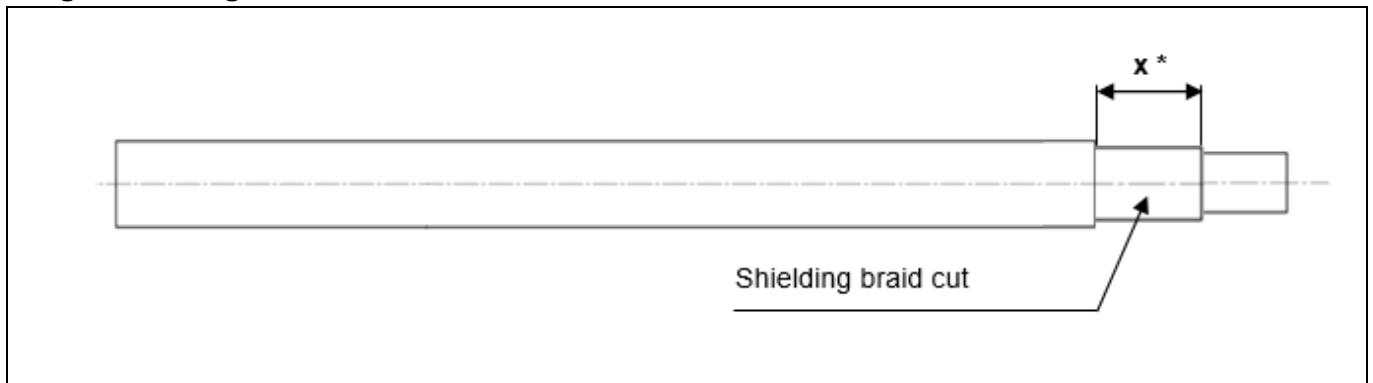

\*Dimension x can vary, depending on the production-method of each confectioner.

No residues or parts allowed on the cable after cutting the shield netting. This must be ensured with actions like the following:

- Prevention by removing the separated shield netting.
- Prevention by blowing-out or suction residues / parts from the shield netting.

Furthermore, it must be guaranteed, that after the next processing step, a 70% overlapping of the shield netting over the position on the stress relief is given.

This document is not subject to change service!



## 3.5 Wire processing II

Put the shielding braid back (Remove foil, if needed.)



Do not cause any mechanical damages on the single conductors during the manufacturing process. If necessary, the twisted shield netting can be dissolved (brushed off).

## 3.6 Assembly I

### Strain relief, shielding braid and shield crimp socket positioned and pressed

Strain relief → Shielding braid needs to be laid out firm.



Shielding crimp socket → Shield crimp socket should not be damaged during positioning.

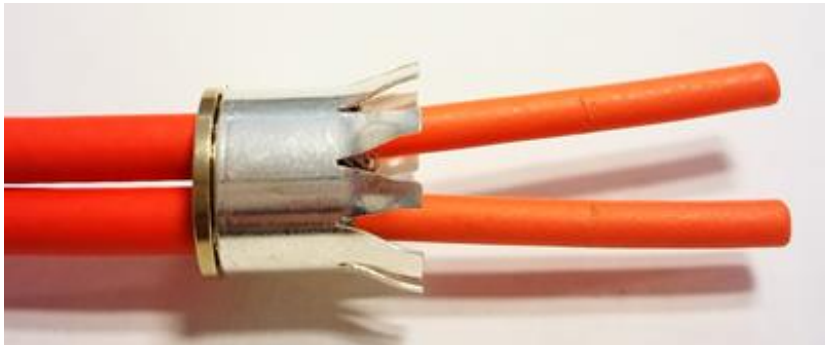

Hexagonal pressing geometry





- **Device for pressing operation**

The device for the pressing operation of the company “WKM” can be used for the exact positioning and pressing operation of the stress relief and the shield crimp socket.

Name of the device: HV - Kabelverpressungsvorrichtung  
Order number: 13 88 02  
Name of the device: Wechselmodul zur Leitungsvorbereitung HCT4

The above-mentioned device was developed and realized according to the process guidelines of Hirschmann Automotive GmbH. Single details, regarding the ordering, handling and process specification can be obtained directly at the manufacturer.

**WKM - Maschinenbau GmbH**  
**Oberes Ried 15**  
**A-6833 Klaus**  
**Tel. +43 5523 / 54907**

The ordering of a device for pressing operation is part from the different manufacturers. Therefore, only the pressing operation data will be described in detail in this process specification HPS40-1 2+2 female connector SCC.

- **Pressing operation data**

Dimensional parameters:

**Hirschmann Automotive GmbH HCT4 female terminal:**

- a) The strain relief, shielding braid and shield crimp socket must be positioned in the device in a correct and precise position in relation to the wire end with the straight cut.  
(Dimension L5 =  $39.65 \pm 1$  mm).
- b) The circularity of the shield crimp socket must be guaranteed.
- c) Before and after pressing operation, the specified dimensions on the following drawing 1 must be kept.

This document is not subject to change service!



Drawing 1

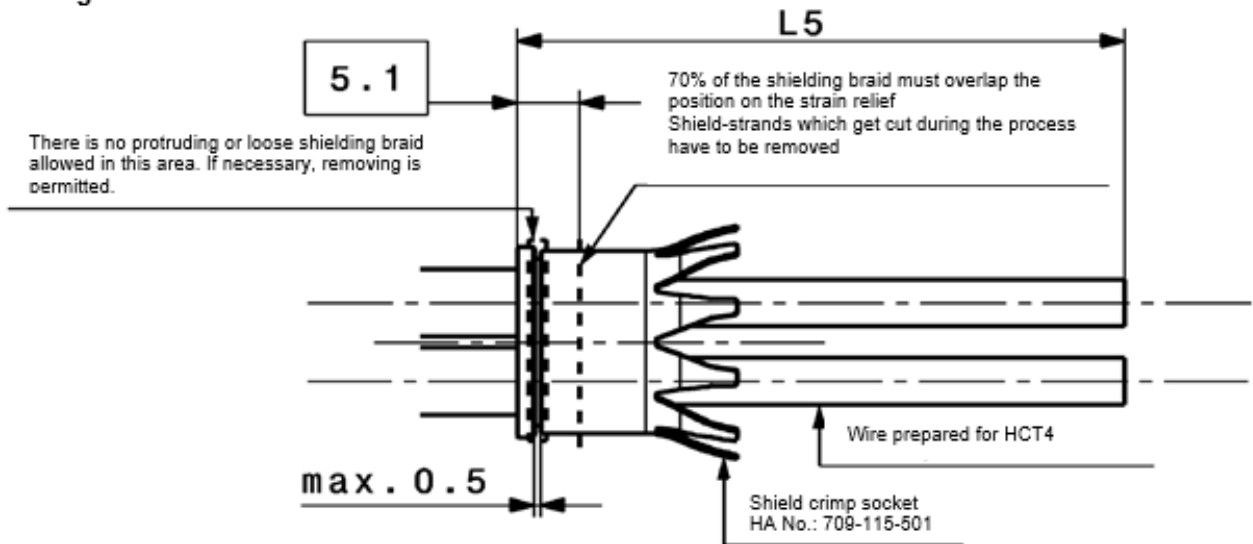

HCT4 incl. zero-cut add on	L5 = 39,65 mm
HCT4 excl. zero-cut add on	L5 = 35.65 mm

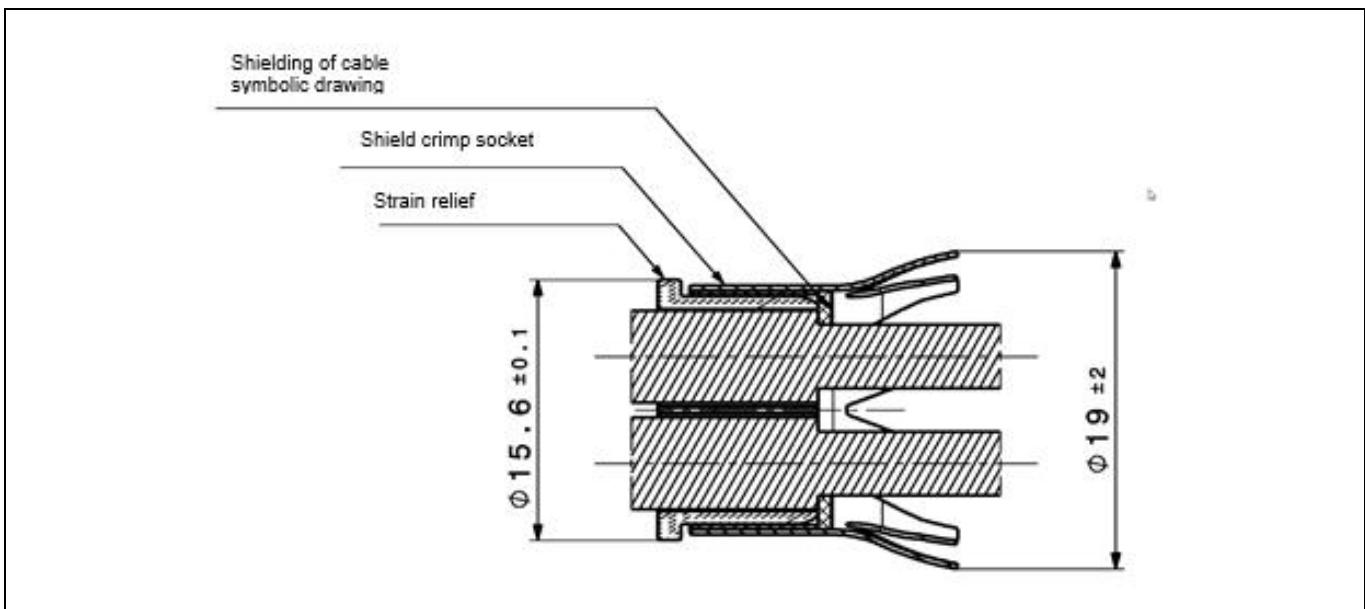

This document is not subject to change service!



- **Pressing operation geometry**

Hexagonal geometry of pressing operation

**Position of pressing operation:**

	Wire cross section	Dimension c (mm)
	3.0 mm <sup>2</sup>	5.7 ± 0.3
	5.0 mm <sup>2</sup>	5.7 ± 0.3

**Depth of pressing operation:**

	Shield relief to shielded cable with shield netting.
--	--

Wire manufacturer	Wire cross section	
	3.0 mm <sup>2</sup>	5.0 mm <sup>2</sup>
<b>Coficab</b>	13.25 ± 0.25	-
<b>Sumitomo Electric Interconnect Products (Suzhou) Ltd.</b>	-	-
<b>Judd Wire Inc.</b>	-	-
<b>Beijing Force Automotive Wire Co.Ltd</b>	-	13.25 ± 0.25
<b>KBE</b>	-	13.50 ± 0.20

Dimension "d" in mm

\*The upper tolerance of the pressing depth can be raised, until the presented value, if it is not possible to change the settings on the machine. But then the manufacturer must ensure that the isolation of the wire is not getting pulled back of the strain relief while assembling it into the locking device. Additionally, the locking position of the shield crimp socket must be reached.

This document is not subject to change service!

- **Check measurement of the depth of the pressing operation**

Use the measurement device to ensure the depth of the pressing operation is correct: to check dimension “d”, all three depths (A-A, B-B and C-C) must be measured. All measurement values must be within the given tolerance.

The measuring must be done with a point micrometer  
(Manufacturer Mitutoyo, measuring range 0-25 mm, measuring point 15°/R 0.30 mm).

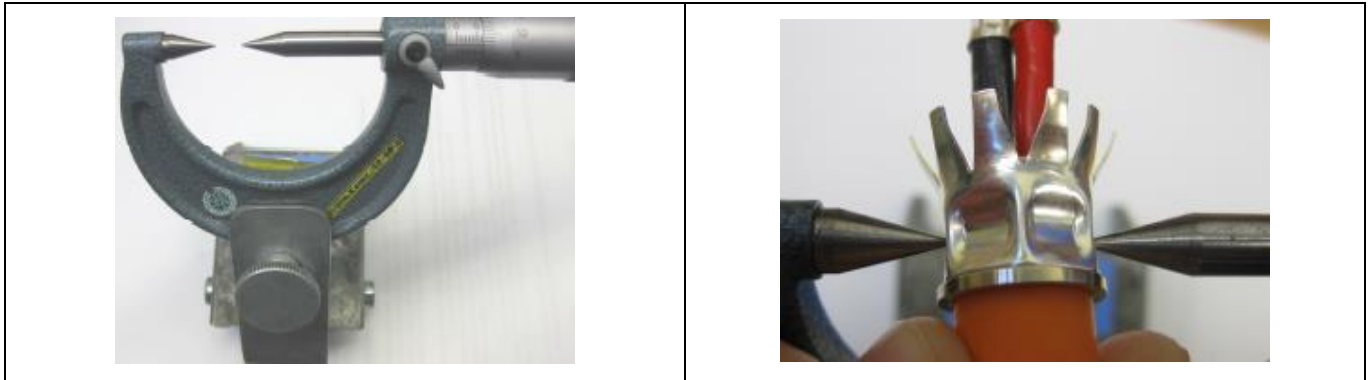

Position measuring points: center to center





### Pull-off-force with shield netting

The pull-off test with netted shield must be carried out.

Wire cross section	Pull-off force
3.0 mm <sup>2</sup>	≥ 50 N
5.0 mm <sup>2</sup>	≥ 50 N

### Pull-off-force without shield netting

The pull-off test without a netted shield does not have to be carried out and only serves as an additional indication of positive processing.

Wire cross section	Pull-off force
3.0 mm <sup>2</sup>	≥ 30 N
5.0 mm <sup>2</sup>	≥ 30 N

### General specifications

Do not cause any mechanical damages on the following parts during the pressing operation.

- Isolation of shielded cable
- Isolation of single conductors
- Shield crimp socket
- Shield netting

This document is not subject to change service!

### 3.7 Assembly II - female terminal HCT4

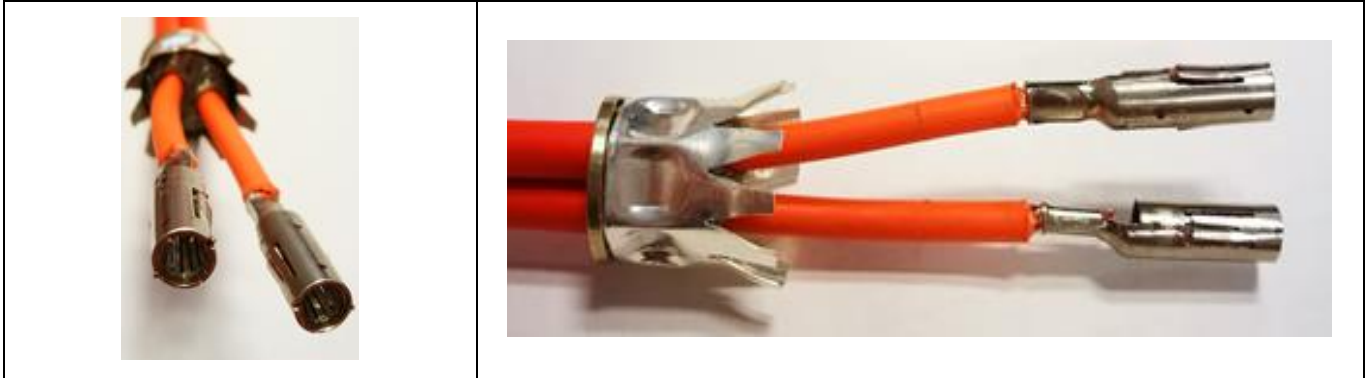

- **Double stroke crimping machine**

The crimping device by the company “Schäfer” can be used for the exact positioning and crimping operation of the HCT4 female terminal.

<u>Name of the device:</u>	Double stroke crimping machine
<u>Article number:</u>	EPS2001-HCT4
<u>Name of the device:</u>	Crimping insert
<u>Article number:</u>	Must be taken from the “Process specification HCT4 female terminal EVS-100068”

The mentioned device was developed and realized according to the processing guidelines by Hirschmann Automotive GmbH. Single details, regarding the ordering, handling and process specification could be enquired directly by the supplier.

**Schäfer Werkzeug- und Sondermaschinenbau GmbH**  
**Dr.-Alfred-Weckesser-Str. 6**  
**76669 Bad Schoenborn-La, Germany**  
**Tel.: +49 7253 9421-0**  
**Fax: +49 7253 9421-94**  
[www.schaefer.biz](http://www.schaefer.biz)

The ordering of a device for pressing operation is part from the different manufacturers. Therefore, only the crimp and position operation data will be described in this process specification HPS40-1 2+2 female connector SCC in detail.

This document is not subject to change service!





- **Process data**

- a) The crimping operation data must be taken from the “process specification HCT4 female terminal EVS-100068”.
- b) The crimping of HCT4 female terminals is related to the shield crimp socket. The relevant wire related length dimension L6 will be created over tool changeable inserts on the crimp press machine. This must be ordered at company Schaefer separately. To mount the polarized HCT4 terminals smoothly into the contact holder, the terminals must be crimped in the correct position to the wire.

The dimensions shown in the following drawing 2 must be observed after crimping.

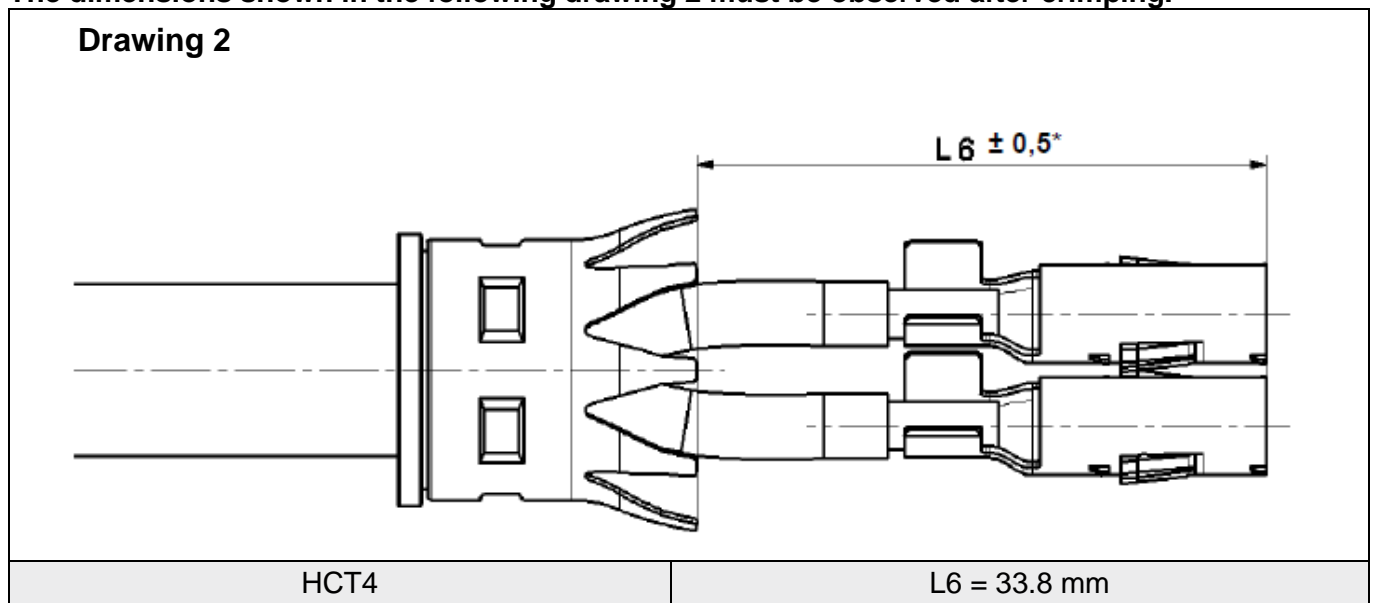

\* For all silicon core cables with silicon insulated single wire the upper tolerance can be increased to +1.7 mm to enable an easier assembly process. The maximum length of 35.5 mm is not allowed to extend, because of the risk of cable damages in case of cable overlength inside of the connector. The minimal cable length must be checked and released with the used assembly equipment for the assembly step. (If necessary, the minimum cable length must be increased to warrant the locking position of the shield crimp socket.)

This document is not subject to change service!

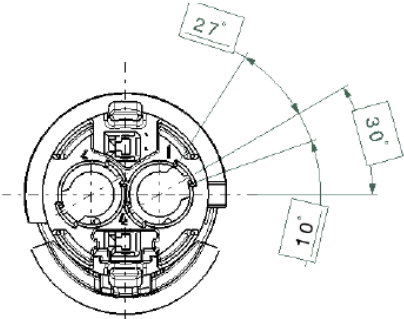
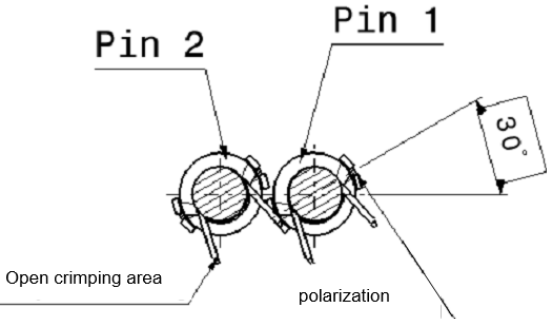

Insertion chamber female terminal HCT4	Nominal position of the terminals of the wire
<i>These angular dimensions are theoretical dimensions and only serve information.</i>	
	

To ensure the correct assembling, primary locking and secondary locking, the crimping of the terminal in the correct position to the wire is important. The nominal angle should be 30°. Depending on the wire the angular deviation can vary.

The allowed angular deviation will be specified by the geometry of the insertion chamber at the female terminal holder and the max. permissible assembly force of the shielded cable with the terminals into the terminal holder. This can be checked during the assembling process.



This document is not subject to change service!



### 3.8 Assembly III

Assemble HCT4 terminals into HPS40-1 contact carrier (1).		
HCT4 terminal	Pin	Polarity/ Colour
	1	+ / Orange
	2	- / Orange

During the assembly of the HCT4 female terminals, the snap latch of the HCT4 female terminal will be deflected. When reaching the final position, the latch will lock audible, and the terminals are primary-locked.

Pre-locking position / primary locked	Press secondary lock (2).
 2 1	 2 1

This document is not subject to change service!



During the assembling process of the HCT4 terminal into the contact holder, a plastic chip can appear inside the terminal chamber. A plastic chip up to 100 µm is permitted and can be left in the connector. The number of plastic chips is not relevant.

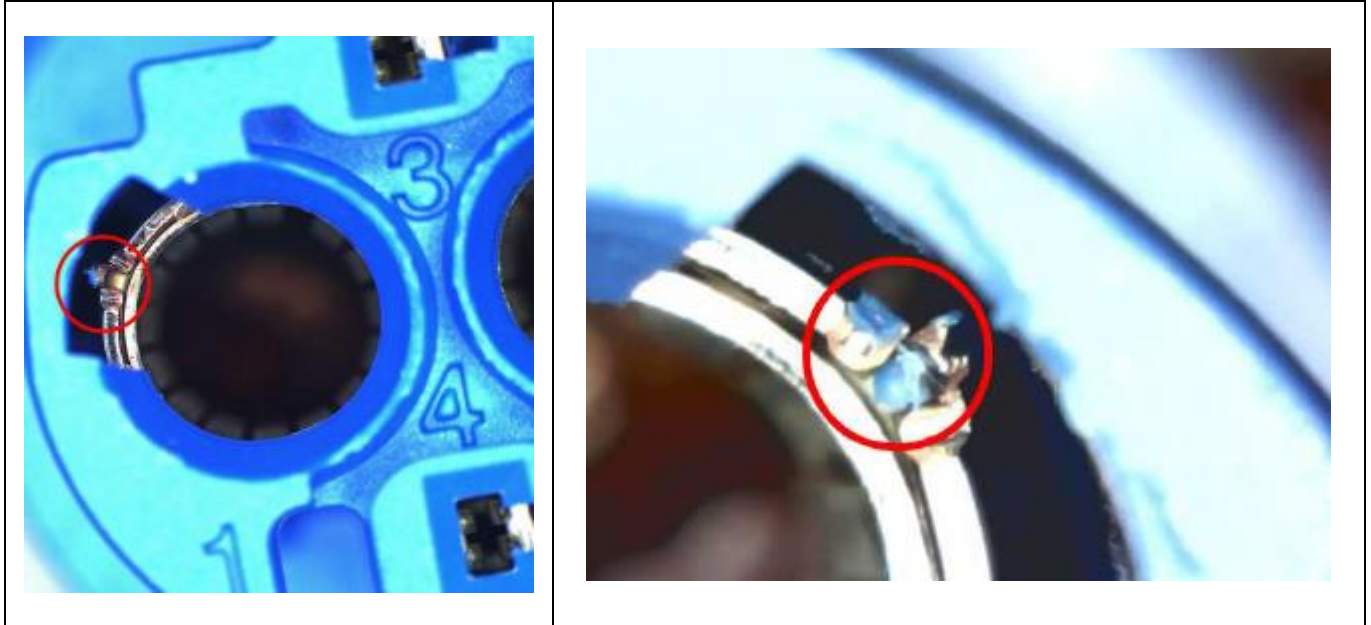

Pictures: HCT4 female contact holder, coding C with plastic chip

Wire manufacturer	Wire cross section	
	3.0 mm <sup>2</sup>	5.0 mm <sup>2</sup>
Assembly-force	30 N	36 N
Coficab	FHLR91XC91X T4	-
Beijing Force Automotive Wire Co.Ltd	-	FORCE-S61-2009 150° C, 600 V
Judd Wire Inc.	-	1C BC XLPO/XLPO, SHIELDED, ISO 150° C, 600 V, HEV
Sumitomo Electric Interconnect Products (Suzhou) Ltd.	SUMITOMO-SZ EXZSW-F 3 150° C, 600 V	-
KBE		FHLR91XC91X T4

This document is not subject to change service!



### 3.9 Positioning locking sleeve unit

Polarized and power-assisted assembly of the locking sleeve unit.

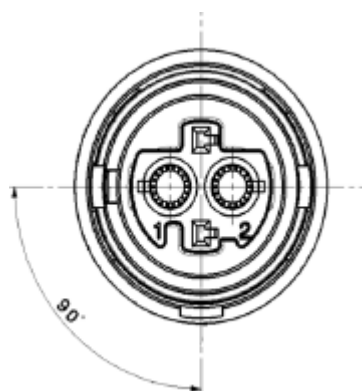
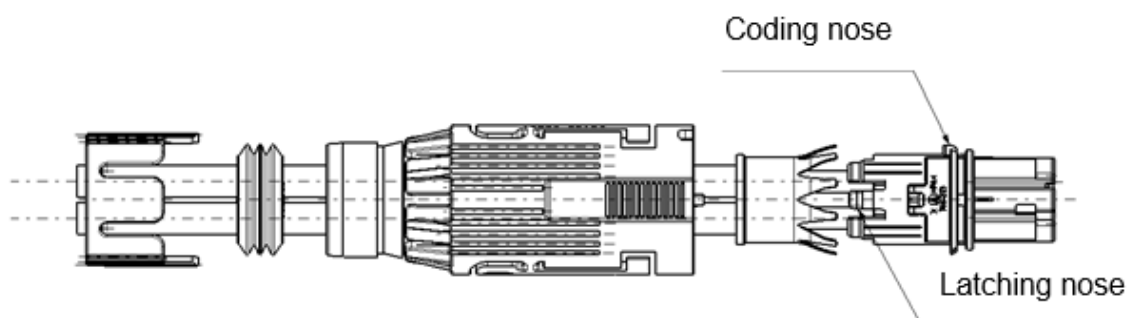

Polarization characteristics  
Locking device unit and terminal holder

The optimal mounting force and the distribution of the force acting, are depending on the different types of the wires. During the machine supported production, the max. forces must be considered, to prevent damage on other components.

This document is not subject to change service!



**Even a compression of the HV single wires and the related risk of damaging the HV wires must be avoided during the assembling process.**

This can be achieved by a simultaneous pull + press and prevent the relative movement between terminal holder and cable. --> max. allowance of the compression of the HV single wire is 1 mm. Alternative it is possible to pull the cable until you reach the end position of the shield crimp socket. In a second step the contact holder must be pushed to achieve the final locking position.

Compressive force (contact holder)

$F_{max} = 200 \text{ N}$  on terminal holder unit

Tensile force (HV cable)

$F_{max} = 120 \text{ N}$  (170N\*) on harness

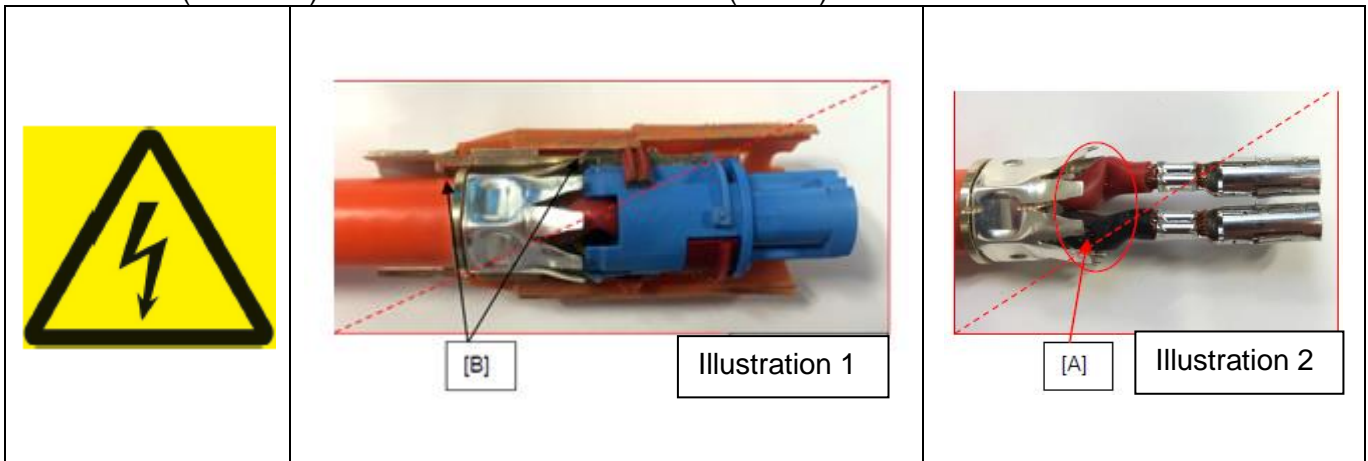

These errors may be caused by cables that are too long, or deviation from the process specification. As a result, wires might be kinked and damaged [A] (risk of short circuit), and incorrect locking position [B] of the shield crimp socket.

- The shield crimp socket, both latching hooks and the latching nose of the terminal holder unit, must be locked in the gaps of the locking device unit.
- There may not occur any damages on the shield crimp socket, the coding nose and both latching noses, during the assembly process. The shield of the HV wire may not be pulled out of the strain relief sleeve.

\*If necessary, the pulling force can be increased to 170 N, if there is no damage on the wire, also the sheath of the wire cannot be loosened of the stress relief.

This document is not subject to change service!



### 3.10 Assembly seal and cover cap

Seal (1) and cover cap (2) have not to be damaged during the assembly process.



Lock cover cap (2) in the cut-out (3) of the locking sleeve unit.  
Cover cap (2) is not locked against rotation.

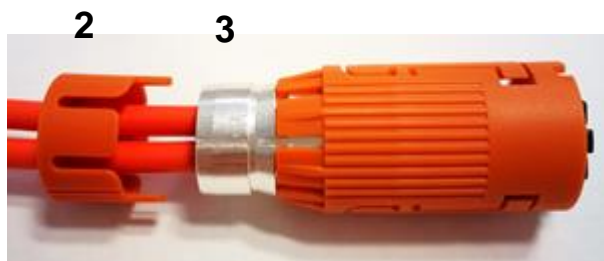

### 3.11 Delivery of produced harnesses

For a capable and controlled process delivery of the produced harnesses to quantitatively free defined bundles.

This document is not subject to change service!

## 4 Technical information

### 4.1 General requirements

It is not allowed, that any damages appear on the single components during the whole production process.

### 4.2 Technical cleanliness

In generally, pay attention to the cleanliness at and inside of the connector. Metallic particles generated at the assembly process must be removed with a suitable measure. No metallic particles  $>1,000 \mu\text{m}$  allowed on the inside neither on the outside of the connector.

Metallic particles at each connector: CCC = N (J4/K0) according to VDA 19

All other particles at each connector: CCC = N (J4/K0) according to VDA 19

This document is not subject to change service!





## 5 Change of documentation

Version	Change description	Change date	Editor
1	Initial edition SCC	05/ 2018	Hoor-Murati R.
2	Added Coficab SCC cable	07/ 2022	Ding S.
3	New design for the process specification Added dimensions and pull-off force for 3.0 mm <sup>2</sup> cable	08/ 2022	Natter T.
4	Change of design	06/ 2023	Jussel E-M.
5	Adjusting data of the bottom line	07/ 2023	Jussel E-M.
6	Page 22: Updated "Pull-off-force with shield netting"- dimension Topic 2.1, Page 20, Page 27: extension line wire manufacturer KBE	10/ 2023	Jussel E-M.
7	Topic 2.4: specified the stress relief PN	05/ 2024	Jussel E-M.