

2.8 SealStar F & M Connector SLK

Completely Watertight, Robust, and
Compact with an Active TPA

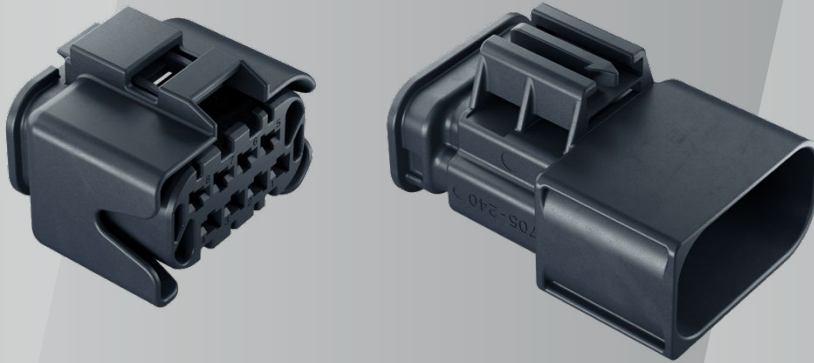

HIRSCHMANN
AUTOMOTIVE

DRIVEN BY QUALITY AND INNOVATION

Lightweight construction is closely linked with efficiency – and our SealStar housings also combine both features.

The connectors are compact and convince with their resistance to external influences.

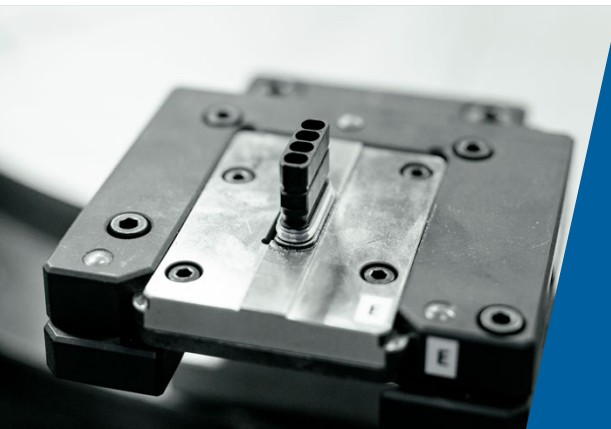

Characteristics Female:

During development we collaborated with renowned OEMs and their system manufacturers. This resulted in products with numerous benefits:

- compliant with test specification LV214
- watertight according to IPx8/IPx9K
- single-wire sealing and robust radial sealing
- CPA (Connector Positioning Assurance)
- completely pre-assembled product
- locking element either right or left of the protective shroud possible
- primary and secondary locking

TECHNICAL PRODUCT INFORMATION

CAVITIES	2 to 8way
TERMINALS/CONTACTS	SLK 2.8 (Kostal)
PITCH	5.0 mm
WIRE SIZE RANGE	max. 2.50 mm ²
LV214 or TLF0214	yes
USCAR2	S2 v S3 ²
IP-CODE	IPx8/IPx9K ²

TEMPERATURE RANGE

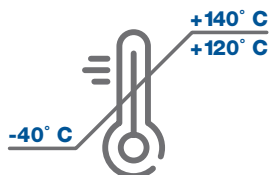

VIBRATION



Characteristics Male:

During development we collaborated with renowned OEMs and their system manufacturers. This resulted in products with numerous benefits:

- compliant with test specification LV214
- watertight according to IPx8/IPx9K
- single-wire sealing and robust radial sealing
- CPA (Connector Positioning Assurance)
- convenient and secure connection with audible feedback of detent function
- completely pre-assembled product
- primary and secondary locking

PRODUCT VARIANTS:



2WAY

CAVITIES	2
TYPE OF PRODUCT	female
NUMBER OF TERMINAL ROWS	1
CPA	yes
STANDARD PRODUCT	yes
CODING OF PRODUCT	A
OTHER CODINGS AVAILABLE	B, C
ORDER/PRODUCT NO.	805-198-521



3WAY

CAVITIES	3
TYPE OF PRODUCT	female
NUMBER OF TERMINAL ROWS	1
CPA	yes
STANDARD PRODUCT	yes
CODING OF PRODUCT	A
ORDER/PRODUCT NO.	805-199-521



4WAY

CAVITIES	4	4
TYPE OF PRODUCT	female	female
NUMBER OF TERMINAL ROWS	1	1
CPA	yes	no
STANDARD PRODUCT	yes	yes
CODING OF PRODUCT	A	A
OTHER CODINGS AVAILABLE	-	B
ORDER/PRODUCT NO.	805-200-521	805-219-521



5WAY

CAVITIES	5
TYPE OF PRODUCT	female
NUMBER OF TERMINAL ROWS	1
CPA	no
STANDARD PRODUCT	yes
CODING OF PRODUCT	A
ORDER/PRODUCT NO.	805-260-541



8WAY

CAVITIES	8	8
TYPE OF PRODUCT	female	male
NUMBER OF TERMINAL ROWS	2	2
CPA	yes	no
STANDARD PRODUCT	yes	yes
CODING OF PRODUCT	A	A
ORDER/PRODUCT NO.	872-585-521	872-586-541

SEEKING MORE DETAILED INFORMATION?
SCAN ME AND VISIT OUR WEBSITE.



ORDER FREE SAMPLES.



**Johannes Ulrich is your Contact
for Individual Questions**

Global Product Manager Low Voltage

 +43 5522 307 1096

 +43 664 386 58 60

 johannes.ulrich@hirschmann-automotive.com



Hirschmann Automotive GmbH

Oberer Paspelsweg 6–8
6830 Rankweil, Austria

www.hirschmann-automotive.com
shop.hirschmann-automotive.com

